

GIGAHERTZ[®] SOLUTIONS

Made in Germany

NFA-SERIES

3D-NF-Analyser with Data Logger

The innovative concept for the field strength measurement technology within the building biology

The NFA1000 requires only very few settings and is able to process hundreds of thousands of pieces of information per second in the background, allowing you to capture the most important parameters at one glance in the process of measuring.

At the same time, all relevant measurement and instrument data are simultaneously and continuously recorded onto a standard SD memory card, linked with the possibility of dictating audio notes „live“ directly into the device. A minimum of effort will therefore provide a maximum of information for a detailed analysis on your PC later on.

This leaves you with more time for the essential task:

The best possible consultation of your customer.

The PC evaluation software „NFAsoft“ included in the scope of supply requires no installation, impressively displays the measuring results, supplies statistical evaluations in real time, and provides all information you need for your measurement protocol in a flash.



The Measurement: „Less is More“!

The NFA only displays the information important for the process of measurement:

- The default display indication is the 3D total pollution.



- Differently coloured LEDs parallelly show the relevant frequency components and a limit value indication.
- Measurement algorithms and audio notes allow for an extremely rational measurement process.
- The NFAs indicate and correct absurd settings.

The Evaluation: „More for More“!

- In order to avoid an uncomplete protocol on your PC due to a lack of details, the NFA is able to capture all frequency and axis related information simultaneously, continuously, and without „blind spots“.
- The high „resolution“ of 10 data records per second as well as the revolutionary PC evaluation software NFAsoft allow for a completely new aspect of the much discussed phenomenon of „dirty power“.

PC Software NFAsoft Included in Delivery

The innovative PC evaluation software: An in-house product developed specifically for the NFA, opening up all possibilities of the NFA to the user.

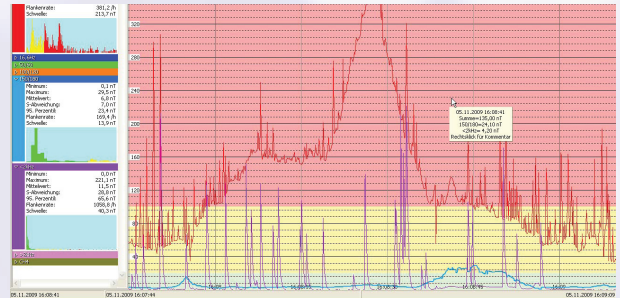

This programme permits a detailed view and analysis of the recorded data, backed up also by the integrated audio notes recorded by the NFA during the process of measurement. Further highlights:

- supplies statistical evaluations of the selected range in real time
- supports the efficient elaboration of informative measurement protocols.

You can define the configuration of your NFA individually according to your principles of operation and your personal preferences in order to optimise your work flow.

The most current version of the software can be found for download on our homepage.

GIGAHERTZ SOLUTIONS
Made in Germany

... patented hightech
... trendsetting innovations !



Potential-free 3D measurement without the „Cube“ - Does that work?

Yes, indeed, it does - with the help of two patented techniques and a few further ideas, we have managed to literally „square the circle“:

- Standardised active sensor covers compensate the differing sizes of the field plate pairs.
- The utilization of parasitic effects of the sensors helps compensate the shortening effect of the long axis.

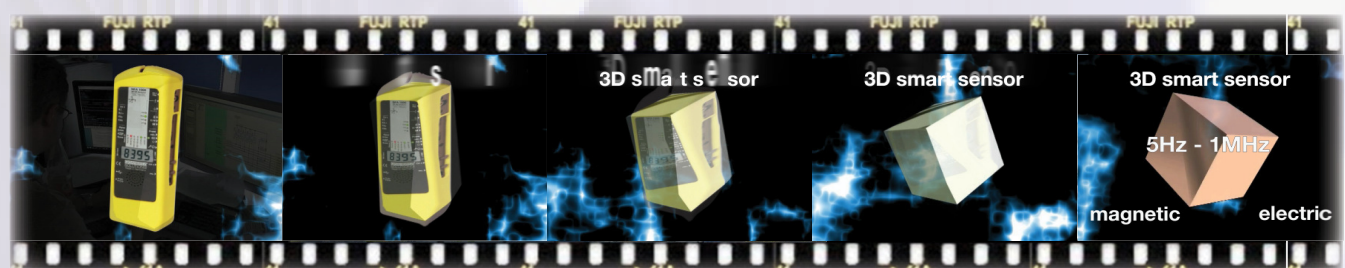

NFA Series

3D LF analysers with data logger



GIGAHERTZ
SOLUTIONS
Made in Germany

3D LF analysers

NFA 30M

NFA 400

NFA 1000

Frequency ranges

Frequency range (from ... to)

16 Hz 5 Hz 5 Hz
32 kHz 400 kHz 1MHz

Frequency selective filter 16.6 | 50/60 | 100/120 | 150/180 | Rest < 2kHz | >2kHz

✓ ✓ ✓

Magnetic flux density

Measuring range "M" in Nanotesla (alternatively displayed in Milligauss)

1 - 19999 nT (up to 400 µT upon request)

Internal 3D sensor (isotropic point < 3cm³) (pat. pend.)

✓ ✓ ✓

Electric field strength

Measurement range in Volt per meter (V/m) Optional range extension upon request

- 0.1 to 1,999 V/m

Internal potential-free 3D-E-field sensor (Patent DE 10 2007 025 911)

✓

Internal potential-free 1D-E-field sensor in Y-direction

✓

Internal sensor bound to earth potential in Y-direction (TCO Recommendation)

✓ ✓

Input for the measurement of capacitive body coupling acc. to SBM (hand electrode opt.)

1 - 19,990 mV

Optional sensors ("CH 4")

TCO compliant E-field sensor (diameter 30 cm, mountable)

opt. opt.

Magnetostatic sensor

opt. opt.

Electrostatic sensor

opt. opt.

Input for AC or DC signals (for instance for the connection of an HF analyser)

✓ ✓ ✓

Signal analysis

True RMS

✓ ✓ ✓

True RMS hold / Peak hold

✓ ✓ ✓

Peak value, broad band (true peak of the wave)

✓ ✓ ✓

Display features

Large LC display (4 digits), also easy to read from afar

✓ ✓ ✓

Frequency indication by differently coloured LEDs or by numerical value

✓ ✓

Acoustic signal (Geiger-counter-effect, volume adjustable)

✓ ✓

Internal data logger

Sampling rate: 110,000 samples/sec., maxima are saved up to 10 times/sec onto the SDHC card. Simultaneous and frequency selective for XYZ and CH4, i.e. without "blind spots".

✓ ✓ ✓

Voice recorder

✓ ✓

Configuration and evaluation software for PC: Innovative graphical and statistical functions, frequency- and axis-specific

✓ ✓ ✓

Instrument "lockable" to assure safe recordings in the case of unauthorised access

✓ ✓ ✓

Scope of supply and optional accessories

Internal Li-Ion battery pack (for up to 48 h "full speed"-recordings, NFA 30M more than 48h)

✓ ✓ ✓

AC-adaptor for quick loading or for mains supply (unlimited recordings possible in this case)

✓ ✓ ✓

Terminal nut for the stand integrated at the bottom of the housing

✓ ✓

Grounding cable

✓ ✓

Floating potential telescopic rod (PM4s) or instrument holder (PM1)

opt. opt.

Compact plastic transport case K5

✓ ✓ ✓

NFA 1000

NFA 400

**3D Low Frequency
Analyser
with Data Logger**



NFAsoft

**Analysis and
Configuration
Software**



Operating Manual

Version 9.0

The THREE-dimensional potentialfree E-field measurement of the NFA 1000 versus the ONE dimensional E field measurement of the NFA400 is the only significant difference between the two meters

Thank you!

We thank you for the confidence you have shown by buying this product. It allows for a professional analysis of AC electric and AC magnetic fields according to internationally recognized guidelines and the recommendations of the building biology.

Technical data and specifications are to be found on our website www.gigahertz-solutions.com.

Contents

| | | |
|---|--------------------------------------|----|
| 1 | Quick Start Guide | 1 |
| 2 | NFA 1000 Front Cover | 2 |
| 3 | LEDs / Display / Audio Signals | 3 |
| 4 | Switches / Push-Buttons / Connectors | 6 |
| 5 | How to Measure and Data-Log | 12 |
| 6 | Power Supply | 15 |
| 7 | „NFAsoft“ | 17 |
| 8 | Firmware-Update | 24 |
| 9 | What if... (FAQ) | 25 |

Do not wipe or touch display foil !

Protect battery: Charge soon after long-term recordings and snap out SD memory card for storage.

Protect from high temperatures and (condensing) humidity

This manual is based on firmware version 91 and NFAsoft version 172.

The firmware and software of the NFA will be continuously improved and made available via download from our homepage.

1 Quick Start Guide

After switching on, the CPU boots, performs some self-tests and then automatically starts measuring. After switching off, please do not turn it back on while the status LED is red to allow the processor to shut down properly.

Set all switches to their top position! (Auto, tRMS, M3D and On)

With these settings you will achieve your first meaningful results without further knowledge about the instrument.

The LCD display will now indicate the **3D magnetic field strength**. The coloured frequency LEDs above the LCD display show the comprised frequencies. The dominant axis x, y or z is indicated by a red LED on the right of the LCD display.

NFA 1000:

To measure the **E-field with ground-reference** simply connect the grounding cable. The NFA detects the attached cable and automatically shows the corresponding electric field strength and frequencies. The 'mode' button toggles between this and the 3D magnetic field.

To measure the **three dimensional potential-free AC electric field**, switch to **E3D** and fix the instrument onto a potential-free rod or onto a support. The 'mode' button toggles between this and the magnetic Z-axis.

NFA 400:

For an E-field measurement, simply switch to **Ey**.

- If the grounding cable is plugged in and connected to the ground potential, you are measuring "against ground".
- If you attach the meter to a potential-free rod or place it onto a support, you are measuring "potential free".
- The 'mode' button toggles between this and the 3D magnetic field.

For data analysis ...

... unzip NFAsoft, double-click and follow intuition!

Should the meter not do what you expect...

... Please have a look the FAQs (page 26ff).

Note:

To allow a simplified freehand measurement, the meter is pre-adjusted with a 16 Hz high pass filter for the magnetic field and a 50 Hz high pass filter for the electric field (see page 23 for measurements from 5 Hz onwards).

2 Front Cover

Analogous front cover for NFA 1000 and NFA 400

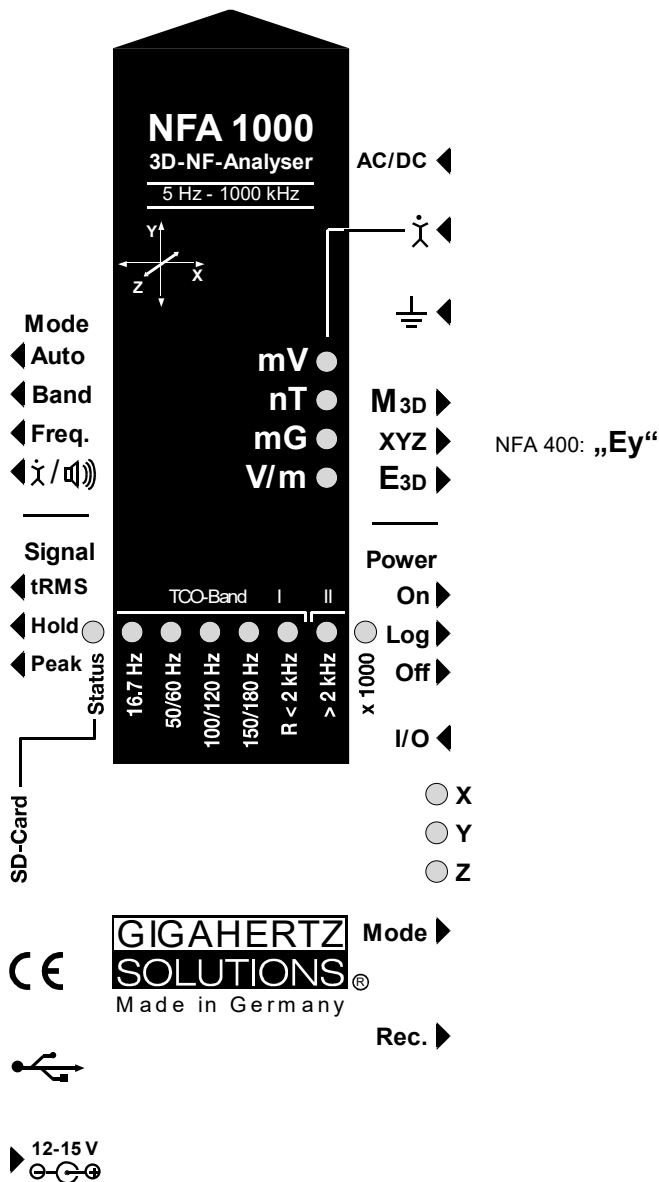

Technical data and specifications are to be found on our website.

3 Display / LEDs / Audio

3.1 Display and LEDs

When switched to “On”, the NFA will briefly show “bAtt” and the remaining battery life. When switched to “Log”, the remaining battery life is shown cyclically with the elapsed log time and name of the log file. After some self-tests the measurement starts automatically.

The remaining runtime display calibrates only after one or two complete charge cycles. Please note: Particularly in the case of a new device and after a longer storage time, the actual remaining runtime may be significantly less than displayed¹.

Time indications are set up as follows:

„Xd.XX“: X days and XX hours or

„XX.XX“: XX hours and XX minutes.

„XX.XX“: (with blinking dot): XX minutes und XX seconds.

1 day, 12 hours is the specified minimum logging time. The real capacity can be higher, in particular with new batteries.

The unit of the reading shown on the LCD is indicated by the adjacent green LED



A flashing LED indicates the unit of a secondary measurement parameter, which can be selected by depressing the “Mode>” button.

If the LCD range for the standard unit is exceeded, the next higher unit is displayed, that is uT instead of nT and Volt instead of mV. Additionally the color of the adjacent LED changes to red and the “x 1000”-LED is also lit red.

LEDs to indicate the applicable frequency bands:

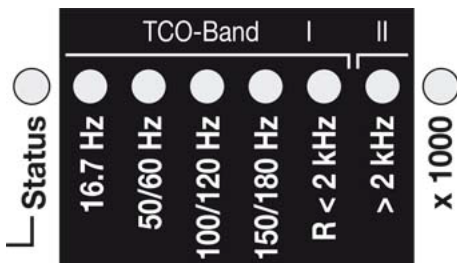

The **frequency-LEDs** change their colour (“traffic light principle”).

”16.7 Hz“: In use for railway lines in some European countries. The reading also includes the 2nd harmonic.

”50/60 Hz“²: Mains frequency. The bandwidth only covers the individual frequency of 50 Hz resp. 60 Hz with its lock-in range.

¹ due to the "unnoticed" loss of capacity in the switched-off state. Snapping out the SD memory card reduces the underlying idle current consumption.

² The NFA automatically detects the mains frequency and adjusts the indication of its harmonics. With “Freq.” the actual mains frequency can be determined exactly. The LED’s for 16.7 Hz, mains frequency and its harmonics up to 2 kHz have a suitable lock-in range to cover mains fluctuations.

"100/120 Hz": This LED indicates the contribution of the second through fourth "even" harmonics. The strongest frequency can be numerically displayed when using "Freq" mode.

"150/180 Hz": This LED indicates the contribution of the third through fourth "uneven" harmonics. The third harmonics will presently be found in many homes and most offices as a significant portion of the total measurement. The frequency of the strongest source can be numerically displayed when using "Freq".

"R < 2kHz": Means "Remainder of frequencies below 2 kHz".

This LED does not show the whole band, but only the sum of all frequencies below 2 kHz which are not covered by the LEDs on the left.

"> 2kHz": Comprises frequencies within the upper TCO-band of 2 KHz up to 1 MHz.

Status LED

The "Status" LED indicates the current mode of operation

"Red" indicates special operating conditions. **Do not switch off** while the Status LED is red!

"Yellow" means "measurement in progress, NO recording".

"Green" means "measurement in progress WITH recording",

Note: with the switch set to "Log.", the "Status"-LED is switched off after a short while, in order to extend battery life.

"x 1000"-LED

Turns red when the scale increases to the superior unit.

Special LCD Display Messages

"Low Batt": Please recharge the battery a.s.a.p. in order to avoid a (harmful) deep discharge.

"Err." = short for 'Error': Indicates an inappropriate configuration. This can occur when a grounding cable or mains adapter is connected AND potential-free E-field measurement is selected.

„----": Autocalibration in progress, processor busy, or the value is too small to be measured reliably.

„CHAR": Instrument is being charged.

„FULL" means: battery fully loaded or SD memory card is full.

„nbAt": The processor cannot recognize the battery (see chapter 9) OR the 15 V AC adapter should be disconnected (the batteries have reached their maximum possible capacity. Storage at this capacity level is not advised)

„Sd-L": short for SD memory card is **L**ocked.

„Sd-F": short for SD memory card **f**ailure". Try re-starting the NFA or re-formatting the memory card according to chapter 9, first paragraph. If necessary, replace SD memory card (max. 16 GB).

There are **two display modes for the frequency-LEDs**:

“Simple/Steady“: (= preset)³

The red LED represents the strongest frequency, and the yellow LED the second strongest. The green LEDs indicate the total frequency range in the current setting.

“Full Information/Volatile“: This makes the LEDs rather unsteady/volatile. (To be configured with NFAsoft)

The proportion of the respective frequency band in relation to the total signal is being displayed. These proportions are shown as follows⁴:

RED = DOMINANT (> 50%)
YELLOW = MEDIUM (< 50%)
GREEN = SMALL (< 10%)

3.2 Audio Signal

The acoustic signal is always linked to the respective measured value and has a „Geiger Counter“ characteristic, i. e. an increasing signal intensity will in turn cause an accelerated rattling sound.

If the “Mode”-switch is set to „
“, clicks on the ‘Mode >’ button turn up the volume and clicks on the ‘Rec. >’ button turn it down (and finally: off), as long as no grounding cable is connected to the instrument.

³ In order to allow for less fluctuations in this mode an internal high pass filter is switched on. With NFAsoft it can be configured to 16.7 and 50 Hz. Experience has shown that the best combination for a freehand measurement is a filter set to 16.7 Hz for magnetic fields and to 50 Hz for electric fields. Electric fields of the 16.7 Hz railway line power frequency (in some European countries) are quite rare indoors and can still be evaluated in the “band” mode. They can still be separately evaluated with NFAsoft.

⁴ To make it more ergonomic for the user, frequencies below the nominal display resolution (that is < 0.1 V/m or < 1 nT) are not indicated by an LED-signal but will still be recorded down to the noise level. Hysteresis: 9/12% resp. 45/50%.

4 Switches / Push-Buttons / Connectors

4.1 On / Off switch (“Power“)

“On” = Standard Measurement Setting

Allow some seconds for self-testing until measurement starts automatically. LEDs and acoustic signal are activated for full information during manual measurements. They remain activated when you start logging by shortly switching to “Log” until the Status-LED is lit green and then back to “On”.

“Log” = Logging / long term recording

All LEDs and the acoustic signal are deactivated in order to save battery life during data logging.

“Off” = Device is off

When turning off the device allow some seconds for shutting down its operating system before switching it back on.

4.2 Field Selection for 3D Measurement

M3D = Magnetic field (3D)

The isotropic point or magnetic field sensors are below the coordinate system printed on the meter faceplate. The dominating axis is indicated by a red LED next to the display.



XYZ = Axis indication

Here, the NFA 1000 will show either the magnetic or the electric field in its three individual components depending on the field type from which the switch was set to “XYZ”, whereas the NFA 400 will only show the individual components of the magnetic field. Press the ‘Mode >’ button to switch from one axis to the other. Please see chapter 4.9 for details to this or to the automated scrolling.

E3D(NFA1000) / Ey(NFA400) = Potential-free E-field

The field sensor pairs for the X-, Y- and Z-axis (directions correspond to the imprint) are situated within the meter close to the housing. For a proper measurement the meter has to be set up more than 12 inches away from any metal objects on an insulated “holder” (accessory PM1) or held with an insulated rod (mounting aid PM5s). Also cables or probes must not be connected during this measurement setting. In the case of an erroneous configuration, the display

will indicate “Err.” until the configuration is corrected or the setting is changed to magnetic field measurement. The measuring person should avoid hectic movements and keep a distance of at least 1.5 m to the object of measurement. For potential-free E-field-measurements the highest accuracy will be reached when used without the yellow silicone holster.

For E-field measurements against earth potential, please plug in the grounding cable and

- switch to “M3D” (automatic adjustment) on the NFA 1000
- switch to “Ey” on the NFA 400.

4.3 Sockets for Inputs and Grounding

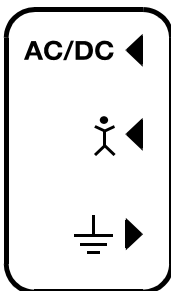

AC/DC = Combined AC/DC-Input

The moment you connect an external sensor, its signal will automatically be displayed in mV and logged if required. (“Mode” switch is set to “Auto”. Protected against overvoltage).

AC: A displayed value of 2000 corresponds to an AC signal of “1V_{RMS}”.

DC: It can linearly display and log signals from +/- 0.1 to +/- 1500mV, i.e. with an HF59B connected and set to coarse (adjust to 1V), the values recorded will be between 1µW/m² and approx. 30,000 µW/m². The value will be displayed in mV⁵.

For logging RF please make sure to remember the settings of the connected HF-Analyser, as they will not be registered by the NFA. You may use the audio note feature for that.

Available options for the AC/DC Socket

Connecting cable for an HF-Analyser for data logging high-frequency (KAB0053). Potentially falsifying LF- or RF-inductions can reliably be suppressed by means of our suppression kit (EDY).

Electrostatic probe for measuring electrostatic charges of surfaces (ES-NFA).

3D-magnetostatic probe for measuring the Earth’s magnetic field and its distortions (MS3-NFA).

An AC signal being connected to the AC/DC socket will by default be displayed as total RMS signal in CH4. For the **analysis and mitigation of dirty power** it is useful to have the signal of a current sensor (“current clamp”) to be split into the frequency ranges of the NFA (FA1). An example for an adequate current sensor is the MiniFlex MA 200 from Chauvin Arnoux.

⁵ For all measurement ranges, even when using an attenuator or amplifier, NFAsoft offers a comfortable conversion tool. The random noise will make it impossible to properly display or record measurement values below 0.1µW/m², though.



This is the only input which cannot be recognized automatically (being single-pole).



Allows the connection of a grounding cable for an E-field measurement with reference to ground (in compliance with TCO). This will be detected automatically by the instrument and the display will change to E-field with reference to ground correspondingly.

Socket for the TCO-conformed probe at the front end of the meter

This is for the TCO-conformed probe available as an optional accessory from Gigahertz Solutions. No data logging!

4.4 Mode = Selection of Measurement Mode

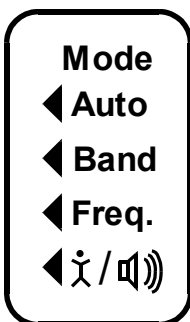

Selects all measurement and display options of the instrument with the field selector switch and the “Mode >” button. Configuration errors will be detected and indicated by “Err.” on the display until resolved.



◀ Band ▶ Freq.

6

Selection of the individual frequency bands is possible by clicking the “Mode” button⁷. Please see chapter 4.9 for more details on this feature or on automated scrolling.

◀  = **Capacitive body coupling / volume**

In this setting, the display will show the signal generated by connecting a hand probe. The grounding cable needs to be connected in order to assure proper measurements. For volume regulation please see chapter 3.2.

4.5 Evaluation of Signal

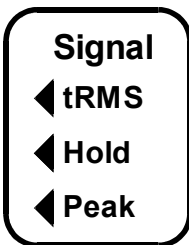

◀ **tRMS** = true RMS value

tRMS = “true Root Mean Square”. The values displayed and recorded can be compared directly to classifications recommended by building biologists.

This is the standard setting of the NFA, even for logging the peak values of an HF-Analyser.

◀ **peak**

Real peak value measurement: With this setting the meter measures the highest culminating point of the wave⁸. A new, still **experimental** measurement feature for building biologists which allows for a more detailed analysis of the LF world in a way which has long since been considered essential in the analysis of RF. This option supplies important information for the evaluation of “Dirty Power” (E-field > 2 kHz).

◀ **Hold**

Retains „tRMS“ or „Peak“ of the signal, depending on the switch position from which „Hold“ was chosen. When the signal switch is set to „Hold“ only the reading on the display is held, the real time value will still be recorded onto the SD card, if recording.

⁶ An exact frequency indication is only possible up to 30 kHz.

⁷ If the 50 Hz high pass filter has been set with the help of the configuration part of the NFAsoft (maybe even as pre-setting), the 16.7 Hz LED will remain unlit. However, the filter only applies to the display in the “Auto”-mode and to loggings in the “All3D”-channel. The aim is to tranquilize the display. Nevertheless, possible frequency components up to 16.7 Hz can be displayed by using “Band” and “Freq.”.

⁸ The resolution of the frequencies during the analysis of the (actually by their nature broadbanded) peak values does not consider phase information (a worst-case consideration). Tolerances are much higher than using the tRMS analysis. It cannot be used with the floating potential E-field measurement for the time being.

4.6 SD Memory Card

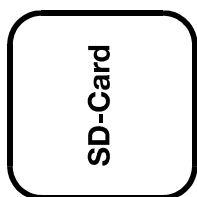

This is the slot for the SD memory card. To prevent the card from accidentally being ejected, slide it in beyond the external surface of the casing until it snaps (use fingernail, if necessary). To extract it press again to undo the snap mechanism.

Your PC will recognize the SD card as an external device when the NFA is connected by USB cable or when it is slid into a card reading device.

Hint:

The SD memory card unfortunately remains the main cause for malfunctions of the NFA so far. There are big differences in quality - we made the best experiences with the following SD card: SANDISK Ultra 16 GB microSDHC card with adapter, 98 MB/sec, Class 10, U1, A1, FFP.

16 GB is enough for three weeks of uninterrupted recording.

4.7 USB Socket

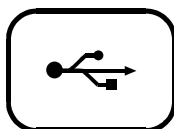

USB 1.0 computer interface connection: Used for meter configuration with NFAsoft. Please take care to have the NFA switched off when connecting or disconnecting the USB-cable!

Please note: for the time being the USB connection works for windows and Linux only!

4.8 Charging Socket

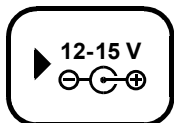

15 V = charge

12 V = measure / log

Over the DC cables that connect the instrument with the AC adapter, in certain situations the measurements can be falsified through stray LF signals or RF overcoupling. There are two options to avoid these falsifications:

- the use of ferrites (of which we offer a low-cost do-it-yourself solution (“EDY”).
- the use of a 12 V external battery (motorcycle gel battery (no lithium!⁹)), we have configured a universal connecting cable for you (“BAK-U”).

⁹ Extensive testing with classical power banks and lithium polymer batteries for flight models showed disappointing results.

4.9 „Mode >“ and „Rec.“ - Buttons for Navigation / Voice Recording

In connection with the “Mode”-switch (left side of the housing) and the switch for selecting the field type, the “Mode” and “Rec.” keys form part of the many special functions of this device.

They are not needed for a simple measurement of the 3D magnetic field.

“Mode” = Toggle Displayed Reading or “Step ahead”

The configuration of the “Mode”-button is **context sensitive**:

If the “Mode”-button on the left is set to “**Auto**”, the NFA recognizes external probes connected to it, and displays their corresponding values.

- The “Mode >”- button toggles the display between the external probe and M3D.
- If no probe is connected to the NFA, “Mode >” toggles between M3D and Ey or E3D and Mz, depending on your selection.

If the “Mode”-button on the left is on “**Band**” or “**Freq.**”,

- Click the “Mode>” button to select the next frequency band (indicated by the corresponding LEDs), and also the axis per band in the “XYZ” mode.
- Click the “Mode>” and “Rec>” buttons at the same time to display the individual axis one after the other in an infinite loop until the “Mode>” button is pressed again.

“Rec” = Record an audio note

Keep this button pressed and so activate the internal microphone to accept your live comments. The microphone is positioned above the “Rec.” button (marked by the hole in the casing lid). It is sufficiently sensitive to pick up audio comments from a few metres distance.

While the “Rec.” button is pressed for taking your notes, these will be recorded in a standard WAV file parallelly to logging value recordings. These audio notes will then be directly allocated by NFAsoft to the corresponding recording times in the graphic.

In order to be correctly allocated by NFAsoft, the WAV files need to be saved in the same folder as the LOG file.

5 How to Measure and Data-Log

5.1 “Live”-Measurement

Of course the meter can be used the “conventional” way: simply switch it on, set the required measurement parameters, and read the values recorded. When operating in the conventional mode, the “Status-LED” will be yellow.

In addition, the device is capable of logging all settings as well as the measurement values of all four channels at once (i.e. the three field axis values plus one additional channel). This data is stored onto an SD-card for future analysis. This function can be activated by temporarily switching the “Power” switch to “Log.” until the status LED turns green. Then switch the “Power” switch back to “On”. Please note: When logging with the power switch set to “LOG” and changing the field of measurement and recording (for instance from M3D to E3D), this will cause the recording session to be closed and a new log file to be created.

These recordings can be annotated by real-time audio recordings which will be assigned automatically to the respective measurement for replay.

The chapters 5.2 and 5.3 are only relevant for the NFA 1000.

5.2 Guided 9 Point Measurement of Sleeping Areas

For alternating electric fields, the guidelines issued by the VDB e.V., Germany, require a detailed analysis of the floating potential electrical field in sleeping areas, specifying nine points (three each in the head-, torso- and foot area, with the outer edge of the instrument located 10 cm off the bed’s edge). The NFA in combination with NFAsoft allows for a “guided measurement” in order to efficiently accomplish data collection and evaluation.

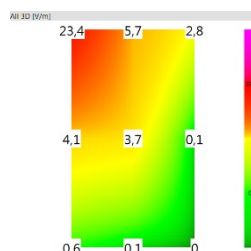

Preparation and start of the measurement:

- Use a potential-free rod (mounting aid PM5s) or the holder PM1 (stabilized by, for instance, a stiff piece of cardboard or a plywood panel).
- Switch the “Power”-button to “On” and choose “E3D”, “Auto” and “tRMS” (choose M3D for magnetic fields).
- Press the “Mode”-button until 9Pt is indicated on the LCD and then let go. A beep will indicate the activation of the 9 point measurement.

The NFA guides the user through the nine points by means of short audio signals (“beeps”). These nine points shall always be processed in the same order, head area: left, middle, right, followed by torso area: left, middle, right and finally feet area: left, middle, right.

- The beeps are not time controlled but the NFA will adjust itself to your personal work rhythm by “sensing” whether it is being moved or it is lying still¹⁰. This way you can finish the nine point measurement within less than a minute or – if you prefer to take it a bit slower – you need not let yourself “be rushed through the measurement by the beeps”.
- The algorithm is as follows: after the activation (see above) the NFA “waits patiently” to be moved (... that is being moved to the first measurement position: top left) and it will not beep to confirm the next measurement before the instrument has been left still in that position for a couple of seconds¹¹ (... in order to pick up a valid measurement). After the beep – *and in your speed* – you can proceed to the next measurement position¹².
- **PLEASE NOTE:** In order to support this algorithm move the NFA more or less rapidly from one measurement position to the next, and “bump” it onto the bed’s surface with a little impact in order to give the transition movement a clear end¹³.
- For an analysis of the collected data use NFAsoft.

5.3 Guided 6-Point-Measurement of Working Places

The NFA and the NFAsoft also support the measurement of working places. In this case six measuring positions are to be collected, as shown in the drawing. For a selection of the working place measurement on the NFA keep the “Mode” button pressed until “6Pt” is displayed on the LCD. For the further procedure follow the instructions of the 9-Point-Measurement in the order: head, elbow, bottom, hands, knees, feet.

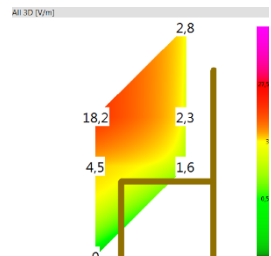

5.4 Long Term Data Logging

A charging time of 12 hours prior to a long-term recording guarantees the maximum possible recording duration and makes independent of the - possibly displayed too high - remaining runtime indication

¹⁰ The interval from beep to beep can vary between 3 and up to 20 seconds according to your work rhythm and movement pattern.

¹¹ This time delay is user-definable with NFAsoft.

¹² After the beep the NFA will wait up to 20 seconds for a movement

¹³ This way the NFA can distinguish more reliably whether it is in motion or kept still. If you use a potential-free rod then try not to move the instrument after you have “hit” the measurement point, if you use a holder then withdraw quickly to a minimum distance of 1.5 m and keep still there in order to avoid movement-induced “pseudo-fields”.

(see footnote 1 on page 3). The interval for recording data is set to 10 full data sets/sec.

The approach in building biology is to record only the AC magnetic field as tRMS.

Recording the E-field leads to little or no additional insight but often produces confusing or meaningless results. Recording E-fields with external power supply does not make any sense at all for obvious reasons.

Initiating Long Term Logging of the Meter

For a long-term recording of several hours or days, set the “Power” switch to “Log”. The status LED will turn green and long-term recording will start off after a few seconds. In this mode the LEDs and the sound are turned off to extend the battery life, after a while also the green status LED. Even if you only want to document a short measurement, please wait for the green status-LED to go out before turning off the NFA, because only then you can be sure that data has been recorded.

The display will show the logfile number (“L...”), the elapsed time of recording as well as the remaining time of use in an infinite loop until the battery is empty or the SD-card full. For information on the display format please see chapter 3.1. When switching back to “On”, recording will be continued without interruption.

The instrument records all data corresponding to its field selection switch. The fourth channel will automatically record the E-field if the field selection switch is set to M3D and the AC/DC socket is not connected. However, if an HF-Analyser is connected to the AC/DC socket, it will automatically record the output of this external device.

“Locking” of the Instrument

“Locking” ensures that the instrument exclusively executes the predefined tasks when left at the customer's place for long-term recordings. To lock, remove and lock the SD memory card while the desired settings are active and re-insert it. The data will still be recorded.

IMPORTANT: Don't forget to “unlock” the SD memory card after finishing a “locked” long term recording!

6 Power Supply

6.1 Internal Rechargeable Battery

The instrument features high performance Lithium Ion rechargeable batteries (2 x 3.7 V). When fully charged, they will last for at least one day and 12 hours of data logging¹⁴.

A vital factor for the durability of Lithium Ion rechargeable batteries is to absolutely avoid a deep discharge and also avoid storage when charged to a maximum. Ideal would be a loading state of around 75%. The NFA setting will prevent a deep discharge in operation, however, in view of the inevitable self-discharge, the meter should never be kept with “almost empty” batteries.

Shelf life without deep discharge with initially $\frac{3}{4}$ -full batteries:

- 3 to >9 Months (the big variations are caused by the varying “off-line” power consumption of SD memory cards)
- >3 years with disconnected SD memory card
- For longer storage the batteries should be disconnected from the instrument.

6.2 Charging

To charge the batteries use the **15 V** AC adaptor. If the device is switched off while charging, the display will show “CHAR” and the estimated running time in the log mode with the current capacity status. Measurements or recordings during the charging process are technically possible, but this is no specified status and thus not recommendable.

When fully loaded, a maximum of one day and 15 h running time will be displayed (“1d15”). Mostly, longer times can be achieved, but this should be considered as “hidden reserve”. Due to the large variation in the Lithium Ion batteries supplied by their manufacturer, the maximum capacity as well as the charging time are subject to fluctuation.

The specified battery life is already reached after a charging period of approx. 8 hours. A (significantly) longer charging period may considerably extend the battery running time.

The maximum capacity will be reached after roughly 15 hours and is indicated by a “FULL” on the display.

“nbAt” on the display indicates that the 15 V AC adapter should be disconnected in order to save the long term battery “health”.

¹⁴ Please note that Li-Ion batteries, even when treated with care, will lose some of their original capacity within one or two years, and their typical life expectancy is 250-500 complete charge cycles. In this case please always replace both batteries.

6.3 Data Logging with External Power Supply

You can perform this task with the supplied **12 V AC adapter**. However, unfavourable conditions may cause falsifications of the measurement through noise, dirty power or RF over coupling. In order to be on the safe side there are two options:

Ring ferrites attached to both ends of the respective cables avoid these falsifications (available from us as a low-cost do-it-yourself solution “EDY”).

Another solution for avoiding these falsifications is the use of an **external 12 V battery** for off-grid long-term recordings. Most suitable for this purpose are standard gel or AGM (motorcycle) batteries (no lithium!¹⁵). We have configured a universal adapter cable for you (“BAK_U”).

The maximum size of a log file that can be opened with NFAsoft (1GB) is reached after 16 days of continuous recording. The longer the logging time exceeds the specified 36 hours, the higher the risk of an unwanted shutdown – mainly caused by the internal electronics of the SD memory card. Longer logging times can therefore not be guaranteed.

Measuring / recording E-fields with an AC adapter or external battery connected – by physical principals – results in meaningless data.

6.4 Battery Change

For safety reasons, please only use original battery packs classified by us (integrated protection circuit). The two battery cells fit tightly, but can – with some patience – easily be removed for the purpose of battery change. In no case untighten the screws of the meter! Putting the meter together is very complicated, and therefore subject to a fee if it needs to be done by one of our technicians.

In order to calibrate the battery life indication on the display, the newly connected batteries need to be either charged until “FULL” appears on the display OR discharged until the NFA switches itself off automatically.



¹⁵ Extensive testing with classical power banks and lithium polymer batteries for flight models showed disappointing results.

7 „NFAsoft“

The provided software allows...

- for the analysis of the data logged by the NFA
- for the configuration of the NFA according to your preferences and habits.



A double-click on the program-icon  opens the window shown on the left. Here you can chose between the tool for the analysis of the data  and the tool for the user-specific configuration of your NFA .

The software is subject to continuous upgrade. The most current revision can be downloaded from our homepage.

System requirements

NFAsoft is made for Windows (98 and up higher). Linux and Mac versions are provided “as is”. **NFAsoft requires no installation** – just pull to location of your choice, double-click and start!

In some cases, it might be necessary to temporarily disable your anti-virus software. Anti-virus software may interpret NFAsoft as a threat and hence might disable or even erase it. It may be necessary to repeat this upon loading an upgraded version of NFAsoft. NFAsoft can be loaded and executed directly form the SD memory card through a card reader or through the USB interface cable. The NFA is supplied with a “Class 6 SDHC”-SD memory card (appropriate readers have been available since 2008, adapters are available for older computers).

7.1 Data Analysis: File Types



A click on the button  opens the program and a Windows-box for file selection. The following file types are available (the consecutive numbering is independent from the file type)

- LOG00001.**TXT** log file (long time recording)
- LOG00002.**9PM** 9-Point-Measurement (sleeping area)
- LOG00003.**6PM** 6-Point-Measurement (workplace)
- REC00004.**WAV** audio file (recorded note).

7.2 Data Analysis: Longterm Recording

Double-click the appropriate log file for analysis. For longterm recordings the following window will open (check chapter 7.2 for 9 point measurements):

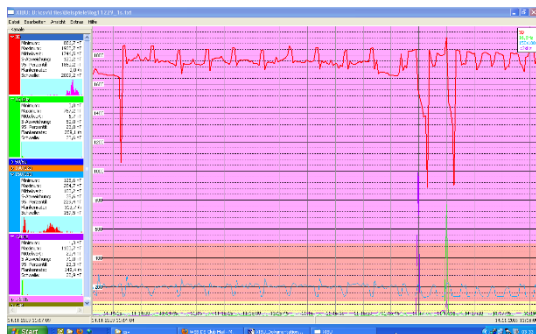

- The far left column labelled "Channels" displays statistic evaluations of the plot on the right (in real-time)

- The graph shows the collected data over time.

- The "x" (horizontal) axis of the plotted data is the time scale and the "y"

(vertical) axis shows the units of measurement corresponding to the field of measurement.

Plotted Data Window



Units of measurement appear on the corresponding channel window on the left and are not indicated on the y-axis. The different plots are colour coded. This allows for different channels to be shown simultaneously.

The x-axis indicates the time span. The figures at the left and the right end of the grey status line show the times of start and end of the logging period.

If the status line is mouse clicked, the window on the right will appear. Here one can enter a preferred time span to view. The time span can also be selected in the "View" menu.

The colouring scheme of the plot corresponds to the standards for building biology measurements (SBM2015):

- Green for "no concern".
- Yellow for "slight concern".
- Red for "severe concern".
- Purple for "extreme concern".

If one selects two channels with different units, the SBM colour scheme of the plot's background will be the one corresponding to the unit of the selected (= bold) channel. It will be bold for the one and regular for the other, equalling the markings in the "Channels" window.

Navigation within the Plotted Data

Within the plotted data you can easily navigate using a mouse and its scroll wheel. Move the mouse pointer into the data plot. The scale of the x-axis will be

- zoomed in when scrolling up or by using the "Up Arrow", zoomed out when scrolling down or by using the "Down Arrow"
- centered around the clock time indicated by the position of the mouse

The data area can be repositioned on the x-axis by a left mouse click hold and drag left or right. You may just as well use the "right" and "left" arrows of the keyboard. Zooming of the time on the x-axis is also possible via the "View" menu.

Scaling of the y-axis is done automatically by default but can be adjusted manually if desired through the “View” menu under “Y-Scale”. You can also adapt the scaling of the y-axis manually via the menu (under “View / Scale”).

Listening to the Audio Notes

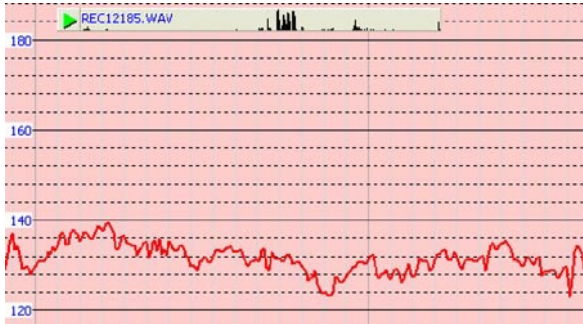

Audio notes dictated during measurement or longterm recordings are shown in the diagram directly at the corresponding point of dictation. Simply click on them in order to listen to the information recorded.

The audio notes will be played back by the audio player of your computer. The grey bar on the top will show the file name and a level preview.

A display of the audio files (.wav) within the diagram is only possible if they are stored in the same folder as the LOG-file and if they are not renamed.

Insert Comments directly into the Diagram

Areas of special interest can be commented directly in the plotted data. Simply position your mouse where you need it, right click and enter your comments in the comment window. When you click Ok, the comment will be embedded into the data, marking an event or section of interest. .

Program Window “Statistics Channels”

To display the data of a particular channel, click the triangle to the left of the channel.

If multiple channels are open, an additional click on the channel information will bold the channel’s plotted data and its statistical data.

The top five values are standard **statistical values**¹⁶. The numerical value “Edges per hour” is used to analyse the number of steeply rising edges, spikes, peaks, pulses, sharp bursts or high frequency transients of the field. The edge thresholds can be defined in the “Channel” menu under “Set edge criteria”. This is an experimental function. PLEASE NOTE: If the 50 Hz high pass filter has been set with the help of the configuration part of NFAssoft (maybe even as pre-setting), this only applies to the channels “All3D”, “AllX”, “AllY”, and “AllZ”. Nevertheless, possible frequency components at 16.7 Hz will also be recorded in the correspondent channel. In this case the sum of the frequency specific channels may well be higher than that of “All3D”.

The light-blue field underneath the statistical channel data represents the frequency distribution of the measured intensities of the

¹⁶ The 95th percentile is calculated heuristically. If the possible deviation exceeds 10%, it will be noted in parenthesis after the figure in absolute terms.

specific channel („**Histogram**“). It is self-scaling and can be interpreted as follows:

- On the left side of the x-axis a formula calculates and plots how often the minimum value has occurred in a given time interval, and similarly on the right side for the maximum value.
- The higher point marks the measured intensity - found most often. The lower points indicate a specific value very seldomly measured.

Menu

Edit

“Copy all“: Copies the plotted data area as well as the drop-down of the “Statistics/Channels“ section into the buffer – from here it can be inserted directly into your measurement protocol at any point of your choice. This is similar to a screen shot. All other edit options are self-explanatory.

View

“Edge Display”

Select the menu option “View/Edge Display” to activate the edge display (displayed as “bar” above the graph). The edge display option will help find important field strength fluctuations. Steep edges are marked in the diagram in the colour corresponding to each channel – the marked channel will be bolded, the others won’t. This way you will always have an overview of what’s going on in the other channels, even if your focal point is, for instance, the 3D-value. The threshold value for an edge display can be defined in the menu option “Channel/Set edge criteria”.

“Set Times”

Select the “Set Times“ option to scale the graphic to a defined time segment.

“Y-Scale“

- Automatic – The y-axis will be scaled automatically to give the best display of the area selected for analysis.
- Manual – The y-axis scaling can be manually controlled in this mode. Allows for and will assist in analyzing small values (e.g. those over 2 kHz) overshadowed by other very strong field intensities.

“**All**” – zooms out the x-axis and displays the complete data set on the data plot. The keyboard “A” keys can alternatively be used.

Use the arrow keys to take over the functions of the mouse.

Channel

Set Edge Criteria (experimental!)

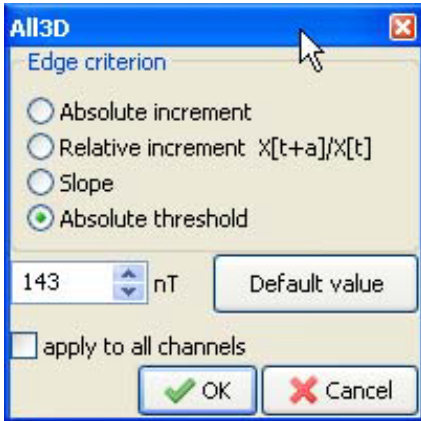

This feature is new and its intention is to facilitate professionals the discussion and analysis of “dirty electricity” beyond today’s definition. Activate “Edge Display” in the menu option “View” to use this function.

This function allows you to define a threshold value with which a spike can be marked directly in the “Edge Display” of the plot. This threshold can be selected individually for every channel. Standard

values have been pre-selected as defaults.

When clicking “Set edge criteria”, the above window will open.

Absolute increment = Marks a rise of the measured field intensity between adjacent points of time by a user defined absolute increment level in V/m, mG or nT

Relative steepness = Marks a rise of the measured field intensity between adjacent points in time by a user defined factor or multiple.

Slope = Marks a rise of the measured field intensity between adjacent points in time by a user defined slope rate in V/m, mG or nT per second. This is independent of the measuring intervals. A hypothetical interval of 1 second would give that increment. This permits to compare results recorded with different recording intervals.

Absolute threshold = Marks a rise of the field intensity between adjacent points in time by a user defined threshold level in V/m, mG or nT. Any rise beyond this absolute threshold value will be marked.

The selected edge criteria will be graphically displayed on the top of the plotted data section and will appear numerically in the field channel statistical data section under edges per hour for that particular time span. All edge markings displayed appear in real time and allow for a quick visual analysis.

When clicking the „ok“ button, the selected criteria and the set value will be transferred into the statistical values of the channel. When re-accessing the menu option “Set edge criteria”, the pre-set values will again be displayed (under construction).

Select HF-Unit

This function will only be displayed when selecting “CH 4” in the “Channels” window and the data recorded in this channel are those of an external input device such as an HF-Analyser (and are therefore recorded in mV).

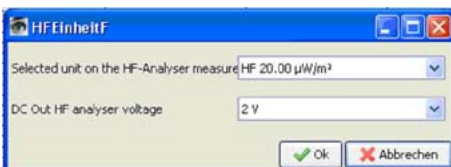

Upon selection of this point of the menu the window shown on the right will open up for a selection of the HF-Analyser settings during the recording period.

For a conversion to mV/m:

Right click with the mouse into the opened channel "HF" and select " $\mu\text{W}/\text{m}^2 \Rightarrow \text{mV}/\text{m}$ " at the very bottom of the following dialog box in order to generate this new channel!

nT <> mG

This function allows to subsequently convert a chosen channel's data from milliGauss to nanoTesla and vice versa.

Convert Units (Experts only!)

Provided "as is" for potential special applications.

Rename or Delete Channel

Allows for a renaming or deleting of the marked channel.

Summarise Channels

The plotted channels (selected on the left) will be added up ("square sum") and added as a new channel. The sum of 100/120 Hz, 150/180 Hz, $R < 2\text{kHz}$ and $> 2\text{kHz}$ are considered to be the relevant parameters for the evaluation of "dirty electricity".

Extras

Create KML-File

Required for the connection of NFA logs with GPS-data and Google Earth. If interested, we will be glad to forward English documentation to this subject. However, we cannot supply any further support.

7.3 Data-Analysis: 9-Point-Measurement / 6-Point Measurement

For a graphical illustration of a recorded 9-point measurement, please use NFAsoft and select the respective file with the extension ".9PM". The illustration is frequency specific. Please note that the readings of the channels X, Y and Z as well as "All CH4" are dependent on the position of the instrument and that the graphical illustration is for orientation purposes only. "Edit" in the menu offers you the possibility to copy the illustrations into your report, also individually. The evaluation of the 6-Point-Measurement is done analogous to the 9-Point-Measurement.

7.4 User-specific Configuration of the NFA



The selected settings can be saved on the SD card as „CONFIG.NFA“. The NFA will then automatically load them

upon its restart. Please note that it is not possible to read the file in order to verify the selected settings of the NFA.

Several customized **pre-settings** for NFAsoft can be defined allowing a quick access. Simply select the settings as required and activate the button “save as pre-setting for NFAsoft”. All pre-settings are stored in the file “NFAsoft.ini” and are available for NFAsoft provided that this file is in the same folder.

For a **synchronization of the time**, connect the

NFA (with SD card!) to the computer with the USB cable. Synchronization happens automatically, as soon as “CONFIG.NFA” is saved to the SD card. If a larger time lag persists, only a new SD card will help (see hint on page 10).

If the **high pass** is set at **50 Hz**, this only refers to the broad band reading or recording as it reduces the influence of movement induced field components. For full information, the frequency components of sinusoidal waves at exactly 16.7 Hz are still recorded separately and can be shown with the help of the NFAsoft.

If the filter is set, it is therefore not unusual for the summary indication “All3D” to be smaller than the indication for 16.7 Hz, as the signal components at 16.7 Hz are not integrated in the total sum of “All3D”.

Furthermore, the signals of the different frequencies are added up quadratically, which in turn means that the result of simply adding the individual signals will also differ from the sum of “All3D”. (For more information on this matter see chapter 9).

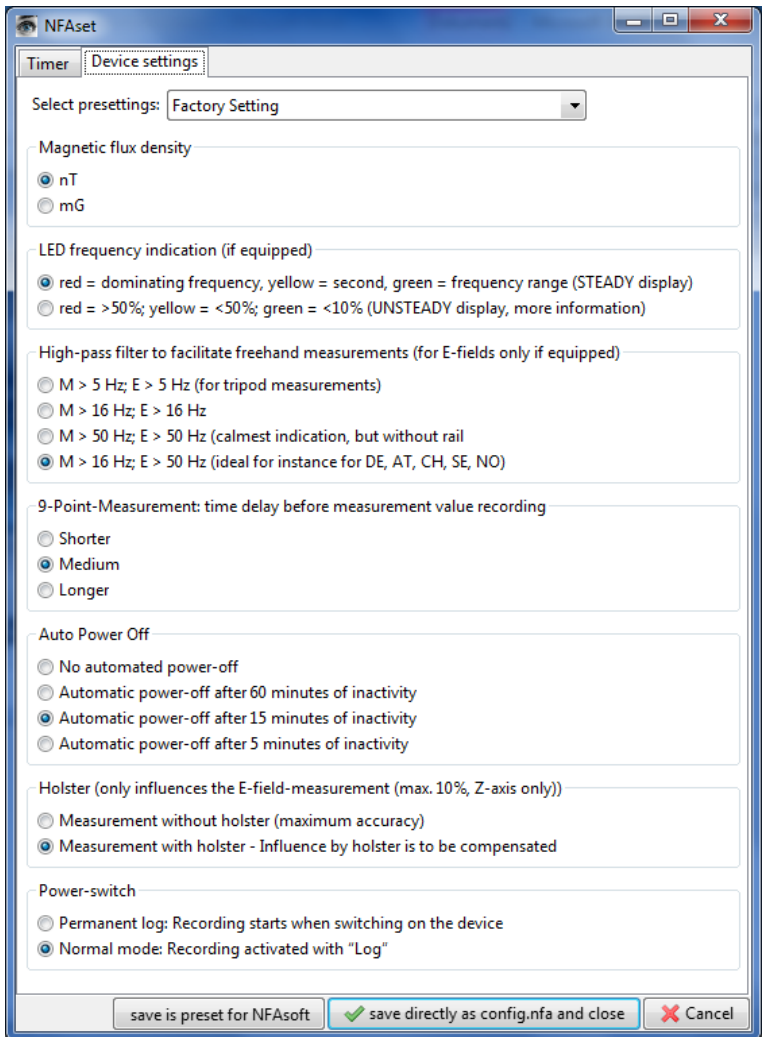

8 Firmware Update

The firmware is the operating system of the NFA. There are always two versions of it in the device's processor: one active and one passive in the background. The latter is overwritten with the new version during the update.

To display the active version, press and hold the "Mode" button when switching on. The current version can be found on our homepage under the menu item "Downloads".

Update Procedure

Save the unzipped "FIRMWARE.NFA" on your SD card. In doing so, overwrite any existing versions on the card. There must be only ONE "FIRMWARE.NFA" on the card and it must not be renamed. It can be deleted from the card after the update.

Lock your SD memory card with the small switch on the left side of the card. Insert SD card into your powered-off NFA. Switch on your NFA. The display will show "CodE", the frequency LEDs will gradually change from green to red during the update process. Then all LEDs will turn off except for the status LED. As soon as the status LED turns green, the update process is completed (this will take a few seconds only).

Do not use any switches and especially do not switch off the meter during the update process!

Don't forget to unlock the SD-card afterwards!

9 What if... (FAQ)

The device does not respond to switching or keystrokes.

Unlock SD card if necessary! (Switch the micro-slide switch on the left of the SD card upwards).

Restart: Switch all switches up, then gently switch off and on.

Doesn't help? See next point...

The NFA cannot be switched on, shows unreasonable remaining runtimes or the display fades.

*Switch on **gently**, stay on SETTING "Log" for approx. 1 sec., only then slide to "On". To start a recording switch back to "Log" from here). Do not log less than 30 sec..*

***Snap out the SD card.** If the NFA then works again, reformat it (see below) or replace it.*

***Recalibrate** the indication of the remaining battery life: Charge for at least 12 h with the 15V power supply. If the target runtime is not reached despite several complete charge cycles, a battery defect is likely.*

***Reset:** Switch off the device, open the battery compartment, CAREFULLY disconnect one of the battery plugs, after about 1 minute (longer is better!) insert the battery again and switch on again.*

Use latest firmware!¹⁷

Reformatting the SD memory card is the most effective remedy in the case of malfunctioning of the NFA. Please save your data and use the original tool published by the SD Association: <https://www.sdcard.org/downloads/index.html>.

Setting:

please note: take care to choose the correct drive!

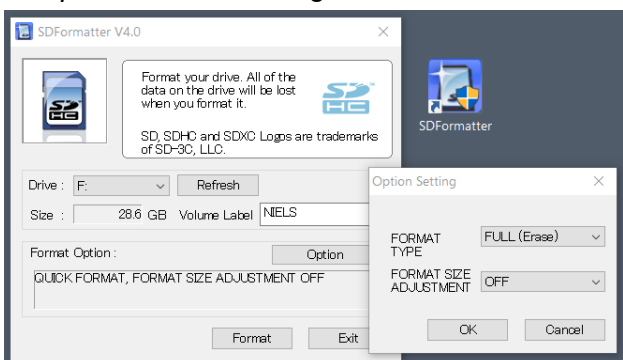

None of that works? Contact us!

¹⁷ The preliminary Firmware of NFA serial numbers below ...0282 cannot be updated (new bootloader).

There is no recording possible (status LED does not turn green)

Insert or unlock SD memory card!

Re-format your SD memory card (see above).

Special Display Messages are explained in chapter 4.

The recorded log file has 0 kb and contains no data

Unfortunately nothing can be done about this retrospectively.

In order to avoid this in future...

... Delete all 0 kb files from the SD memory card on a regular basis.

... Re-format your SD memory card (see above),

... wait after switching off until the red status LED goes out, better longer, before switching on again.

... Never record shorter than 20, better 30 seconds.

... To be on the safe side: Stop recordings by switching "Signal" first before switching off.

A small vertical "Low Batt" indication appears on the display

This is an additional information for the user and is shown once less than 4-8 hours of battery life time are remaining.

An intermittent "Low Batt" indication can be ignored (temporarily increased power consumption due to internal processes).

The meter turns off after quarter of an hour

The auto-power-off interval can be changed in NFAsoft. (Auto-power-off is automatically deactivated while recording).

Time offset in the records

See page 23.

E-field measurement against ground potential is not possible

The field type switch must be switched to "M3D". Now you will automatically be shown the E-field vs. ground potential once you insert a grounding cable. Please see the "quick start guide" at the beginning of this manual for further information.

The meter has four measurement channels which always work simultaneously. Three of them are needed for the 3D measurement, the fourth channel can be used for any other required measurement task.

The sum of the frequency specific channels is higher than the value of “All3D”

The signals of the different frequencies are added up quadratically (square root out of the sum of squares), which means that a simple addition of the individual signals will result in a higher value than the sum of “All3D”. For example, if you take 500 nT at 16.7 Hz plus 1000 nT at 50 Hz, a simple addition will amount to 1500 nT, whereas the quadratical addition (= “All3D”) will amount to only 1118 nT.

The 16.7 Hz LED is off although measurements with “Band” or “Freq.” show values in this frequency

If the 50 Hz high pass filter has been set with the help of the configuration part of NFAsoft (maybe even as pre-setting), the 16.7 Hz LED will remain unlit. However, the filter only applies to the DISPLAY in the “Auto” mode and to recordings made in the “All3D” channel. The aim is to tranquilize the display. Nevertheless, the device may well identify possible frequency components at 16.7 Hz when using “Band” and “Freq.”.

NFAsoft is showing measurement values at 16.7 Hz in spite of the 50 Hz high pass filter being set AND the sum of the 16.7 Hz channel and the other channels is higher than the value of “All3D”

If the 50 Hz high pass filter has been set with the help of the configuration part of NFAsoft, this only applies to the channels “All3D”, “AllX”, “AllY”, and “AllZ”. Nevertheless, possible frequency components at 16.7 Hz will also be recorded in the correspondent channel. In this case the sum of the frequency specific channels may well be higher than that of “All3D”.

The NFA was configured according to customer requirements with NFAsoft, but when restarting, NFAsoft shows the original settings

The “CONFIG.NFA” file on the SD-card transfers user-specific configurations to the NFA. NFAsoft can write this file, but not read it. Therefore you cannot use NFAsoft to check the configuration of the NFA, but only to instal new configurations.

You can save frequently used configurations as presets to a dropdown menu in NFAsoft.

What is the purpose of the individual files and where are they saved?

“CONFIG.NFA” -> user configurations of the NFA-> saved on the SD-card

*“NFAsoft.ini” -> Presettings for NFAsoft -> saved in the same folder as NFAsoft
>>>*

“FIRMWARE.NFA” -> operating system of the NFA -> in the processor of the NFA (only temporarily for updates it needs to be saved to the SD memory card)

9-Point-Measurement of the electric field (“E3D”)...

... in an (almost) field-free area: the indication of the dominant frequency is unpredictable.

In fields of minimal values the indication of the dominant frequency is a matter of pure stochastic

... in an (almost) field-free area there is still a reading on the LCD

The function “Peak” does not work in combination with “E3D”.

When using a telescopic rod, a reading may well be caused by either movement-induced fields or alternating electrostatic fields from your contact with the rod.

Solution: The configuration part of NFAsoft allows to set the high pass filter at 16 Hz or 50 Hz. This will suppress most of these “pseudo fields”, the 50 Hz filter of course more so than the 16 Hz filter. In areas where the 16.7 Hz frequency is not used for traction power you should choose the 50 Hz filter.

... in an (almost) field-free area and using the equipment holder PM1 the evaluation with NFAsoft still shows high values at usually only one point, especially in the “R<2k” channel which does not usually show up during a “normal” measurement

This is nearly always a matter of “pseudo fields” caused by movements or electrostatics in the area of the meter (for instance by the person moving away from the measurement device). Please check chapter 5.2 for more details on the conduction of a proper measurement avoiding this effect.

These pseudo-readings can be deleted from the graph by opening the 9PM-file with a text editor and replacing the odd value.

Small optical defects of the display cannot be completely avoided.

In order to assure the high resolution of the potential free E-field measurement, there is a microscopic metal-printed grid on the foil placed over the actual LCD (not to be confused with the soft protective foil that is easily removable). The foil as well as the electronics are sensitive to humidity, touch and/or heat.

***For that reason:
do not leave meter in a hot car, protect from humidity
(also condensing air humidity), don't wipe or touch
the display foil.***

There are very many small TXT-files on the SD-card?

Solution 1: You have activated the function “permanent logging”, which causes the meter to log not only when switched to “Log”. This option will cause a new file to be started and saved each time the meter is switched on, and each time you toggle between modes.

Solution 2: There is a file system error on your SD-card. In this case, save the “good” files and re-format your SD-card using the original SD-formatter.

Please delete 0 kB files in regular intervals!

An existing audio note it is not shown in the diagram window of NFAsoft.

The audio files (.wav) will only be displayed in the diagram if they are stored in the same folder as the LOG-file and if they are not renamed.

Manufacturer

Gigahertz Solutions GmbH
Im Kessel 2
90579 Langenzenn

Germany

Tel : +49 (9101) 9093-0

Fax : +49 (9101) 9093-23

www.gigahertz-solutions.com

Your local partner